



# YSP ELECTRONIC PRESSURE SWITCH

---

Instructions for Use

## Contents

<b>1</b>	<b>About these instructions</b>	<b>4</b>
1.1	Target groups	4
1.2	Explanation of symbols	4
1.3	Other documents	4
1.4	Feedback about these instructions	4
<b>2</b>	<b>For your safety</b>	<b>5</b>
2.1	Intended use	5
2.2	Obvious misuse	5
2.3	General safety instructions	5
<b>3</b>	<b>Product description</b>	<b>6</b>
3.1	Device overview	6
3.2	Properties and features	6
3.3	Operating and display functions	6
3.4	Operating principle	7
3.5	Functions and operating modes	7
3.5.1	Setting options	7
3.5.2	Normal Mode — Run Mode	7
3.5.3	Programming mode	7
3.5.4	Output functions — switching output	7
3.5.5	Output functions — switching output in Legacy Mode	9
4.5.6	Output functions — analog output	10
4.5.7	Auto detect function	11
<b>4</b>	<b>Mounting</b>	<b>11</b>
<b>5</b>	<b>Connecting</b>	<b>12</b>
5.1	Wiring diagrams	12
<b>6</b>	<b>Commissioning</b>	<b>12</b>
<b>7</b>	<b>Operation</b>	<b>13</b>
7.1	LEDs — operation	13
7.2	Display indications	13
<b>8</b>	<b>Setting and parameterization</b>	<b>14</b>
8.1	Settable functions and properties	14
8.2	Setting parameter values	15
8.3	Unlocking the device	15
8.4	Locking the device	15
8.5	Protecting the sensor with a password	16

<b>8.6</b>	<b>Standard menu guidance</b>	<b>16</b>
8.6.1	Parameters in the main menu	19
8.6.2	Parameters in the OUT... (outputs) submenu	19
8.6.3	Parameters in the DISP (display) submenu	20
8.6.4	Parameters in the EF submenu (Extended Functions)	21
<b>8.7</b>	<b>Legacy Mode</b>	<b>22</b>
8.7.1	Legacy Mode — parameters in the main menu	24
8.7.2	Legacy Mode — parameters in the EF (extended functions) submenu	25
<b>9</b>	<b>Troubleshooting</b>	<b>27</b>
<b>10</b>	<b>Maintenance</b>	<b>28</b>
<b>11</b>	<b>Repair</b>	<b>28</b>
11.1	Returning devices	28
<b>12</b>	<b>Disposal</b>	<b>27</b>

## 1 About these instructions

These instructions describe the setup, functions and use of the product and help you to operate the product according to its intended purpose. Read these instructions carefully before using the product. This will prevent the risk of personal injury and damage to property. Keep these instructions safe during the service life of the product. If the product is passed on, pass on these instructions as well.

### 1.1 Target groups

These instructions are aimed a qualified personal and must be carefully read by anyone mounting, commissioning, operating, maintaining, dismantling or disposing of the device.

### 1.2 Explanation of symbols

The following symbols are used in these instructions:



#### **DANGER**

DANGER indicates a hazardous situation with a high level of risk, which, if not avoided, will result in death or serious injury.



#### **WARNING**

WARNING indicates a hazardous situation with a medium level of risk, which, if not avoided, will result in death or serious injury.



#### **CAUTION**

CAUTION indicates a hazardous situation with a medium level of risk, which, if not avoided, will result in moderate or minor injury.



#### **NOTICE**

CAUTION indicates a situation which, if not avoided, may cause damage to property.



#### **NOTE**

NOTE indicates tips, recommendations and important information about special action steps and issues. The notes simplify your work and help you to avoid additional work.



#### **MANDATORY ACTION**

This symbol denotes actions that the user must carry out.



#### **RESULT OF ACTION**

This symbol denotes the relevant results of an action.

### 1.3 Other documents

Besides this document the following material can be found on the Internet at [www.georgin.com](http://www.georgin.com):

- Data sheet
- Quick Start Guide
- Declaration of conformity

### 1.4 Feedback about these instructions

We make every effort to ensure that these instructions are as informative and as clear as possible. If you have any suggestions for improving the design or if some information is missing in the document, please send your suggestions to [marketing@georgin.com](mailto:marketing@georgin.com).

## 2 For your safety

The product is designed according to state of the art technology. Residual hazards, however, still exist. Observe the following safety instructions and warnings in order to prevent danger to persons and property. Turck accepts no liability for damage caused by failure to observe these safety instructions.

### 2.1 Intended use

The pressure sensors in the YSP product series monitor media in fluid group 2 and indicate the measured values via a display. The sensors are vacuum-tight.

The device must only be used as described in these instructions. Any other use is not in accordance with the intended use. Georjin accepts no liability for any resulting damage.

### 2.2 Obvious misuse

The devices are not safety components and must not be used for personal or property protection.

### 2.3 General safety instructions

- The device meets the EMC requirements for the industrial areas. When used in residential areas, take measures to prevent radio frequency interference.
- The device must only be fitted, installed, operated, parameterized and maintained by trained and qualified personnel.
- Only use the device in compliance with the applicable national and international regulations, standards and laws.
- The max. permissible overpressure must not be exceeded.
- Check the compatibility of the medium and the media-contacting parts.

### 3 Product description

The pressure sensors in the YSP series are incorporated in metal housing and are available with various pressure process connections. The housing can be aligned and fixed before or after installation. All devices have a metal M12 connector to connect the sensor cable. The device settings can be configured via touchpads. The measured pressure can be displayed in bar, psi, kPa, MPa or ten other units of pressure (Ud1...Ud10).

Devices with the following output functions are available:

- YSP : two switching outputs (PNP/NPN) or one switching output (PNP/NPN) and one analog output (can be set as current output or voltage output)

#### 3.1 Device overview

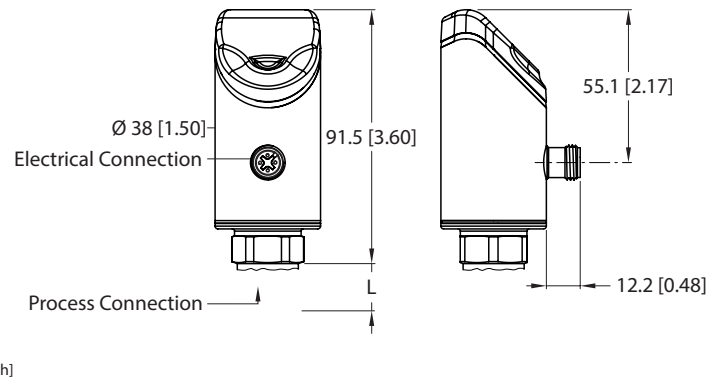

Fig. 2: Dimensions (mm)

#### 3.2 Properties and features

- Pressure monitoring of fluid group 2
- Automatic signal detection
- Up to seven-time overpressure resistance
- Protection classes IP66, IP67, IP69K
- 180° reversible 12-segment display
- Rotatable sensor body
- Housing material: 1.4404 (AISI 316L)/Grilamid TR90 UV

#### 3.3 Operating and display functions

The front of the device is provided with three touchpads [ENTER], [MODE] and [SET], a 4-digit 12-segment multicolor display and status LEDs. This enables the user to set all essential functions and properties directly on the device and read the actual process values and set switching points.

#### 3.4 Operating principle

The pressure sensors in the YSP series work with fully welded metal measuring cells. As a result of the pressure acting on metal substrate, a signal that is proportional to the pressure is generated and processed electronically. The processed signal is available as either a switching output or an analog output with an accuracy of 0.5 % of full scale.

## 3.5 Functions and operating modes

The pressure sensors monitor media and indicate the measured values via a display.

The sensors can be operated in Normal Mode (factory setting) or in Legacy Mode. In Normal Mode, Single Point Mode (SPM), Two Point Mode (TPM) or Window Mode (WIn) can be set for the switching outputs. In Single Point Mode, a limit value is set at which the selected switching output changes its switching state. In Two Point Mode, a lower and an upper limit are set at which the selected switching output changes its switching state as the process value rises or falls. In Window Mode, a lower and an upper window limit are set. Outside the window, the selected switching output changes its switching state. In Legacy Mode, a window function or a hysteresis function can be defined for the switching outputs. The output range of the analog output can be defined as required. The measured pressure is displayed in bar, psi, kPa, MPa and ten other units of pressure (Ud1...Ud10).

Type	Output
YSP	Two switching outputs (PNP/NPN/Auto) or one switching output (PNP/NPN/Auto) and one analog output (I/U/Auto)

### 3.5.1 Setting options

The device can be factory set and remain at any time programmable via touchpads

### 3.5.2 Normal Mode — Run Mode

The sensor detects the system pressures and shows the measured process values according to the preset switching and analog behavior. The display indicates the system pressure present, the selected unit and the status of the switching outputs present.

### 3.5.3 Programming mode

When the sensor is unlocked, the display will go into programming mode after the user presses the [MODE] touchpad. In programming mode, all parameters and their corresponding values can be read out and changed. The values for a parameter are displayed by briefly pressing the [ENTER] touchpad. The [MODE] and [SET] touchpads are used to navigate within programming mode. For more information, refer to the chapter "Setting and parameterization."

### 3.5.4 Output functions — switching output

The switching logic can be inverted via the touchpad (parameter LOGI). The following examples apply to the **HIGH** (0 → 1) switching logic.

#### Single point mode

In single point mode, the switching behavior is defined via a SP1 limit value and a hysteresis. The output changes its switching state at limit value SP1.

The hysteresis can be set via IO-Link or via the touchpad (parameter HYST) and must be within the detection range.

If the process value increases, the switching output is inactive as long as the process value is between the start of the detection range and the SP1 limit value. If the process value increases above the SP1 limit value, the switching output becomes active.

If the process value decreases, the switching output is active as long as the process value is between the end of the detection range and the SP1 limit minus the set hysteresis (SP1-Hyst). If the process value decreases below the limit value (SP1-Hyst), the switching output becomes inactive.

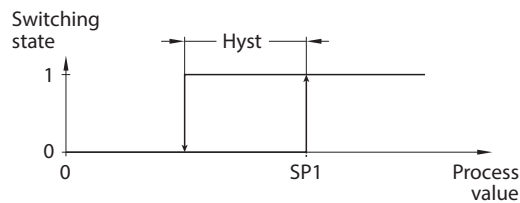

Fig. 4: Single point mode

## Two point mode

In two point mode, the switching behavior is defined via a switch-on point SP1 and a switch-off point SP2. This mode can also be used as a freely adjustable hysteresis.

If the process value increases, the switching output is inactive as long as the process value is between the start of the detection range and the switch-on point SP1. If the process value rises above the switch-on point SP1, the switching output becomes active.

If the process value decreases, the switching output is active as long as the process value is between the end of the detection range and the SP2 switch-off point. If the process value decreases below the switch-off point SP2, the switching output becomes inactive.

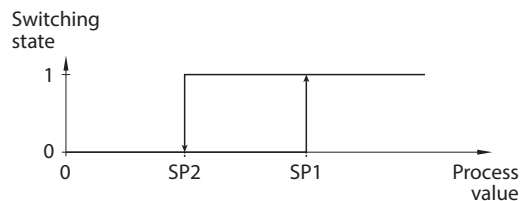

Fig. 5: Two point mode

## Window mode

In window mode, an upper and lower window limit are set for the switching output. A hysteresis can be set for the window limits SP1 and SP2. The switching window must be within the detection range.

The hysteresis can be set via the touchpad (parameter HYST) and must be within the detection range.

If the process value increases, the switching output is inactive as long as the process value is between the start of the detection range and the window limit SP2. The switching output remains active until the process value increases above the window limit SP1 plus the hysteresis (SP1+Hyst). If the process value increases above (SP1+Hyst), the switching output becomes inactive again.

If the process value decreases, the switching output is inactive as long as the process value is between the end of the detection range and the window limit SP1. The switching output remains active until the process value decreases below the window limit SP2 minus the hysteresis (SP2-Hyst). If the process value decreases below (SP2- Hyst), the switching output becomes inactive again.

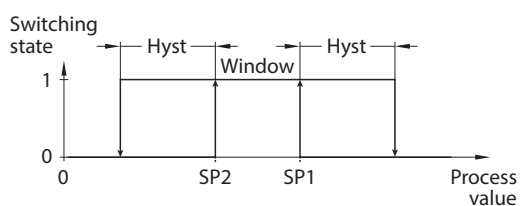

Fig. 6: Window mode

### 3.5.5 Output functions — switching output in Legacy Mode

A window function and a hysteresis function can be set for the switching outputs.

#### Window function

The window function is used to set a switching range in which the switching output takes on a defined switching state. The switching range is defined by means of an upper (FH) and lower limit (FL). The minimum distance between the limit values is 0.5 % of the measuring range. The release point is automatically adjusted if the switching point is changed.

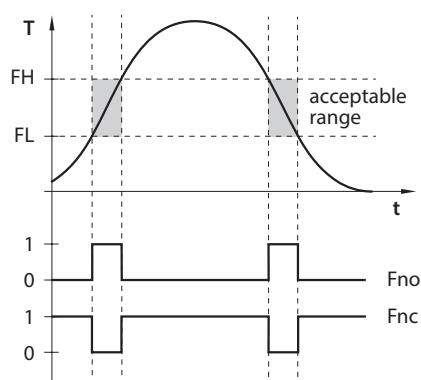

Fig. 7: Behavior of the switching output – Window function

#### Hysteresis function

The hysteresis function is used to set a stable switching state around a setpoint that is independent of system-related temperature fluctuations. The switching range is defined by means of a switching point (SP) and a release point (rP). The minimum hysteresis is 0.5 % of the measuring range. The release point is automatically adjusted if the switching point is changed.

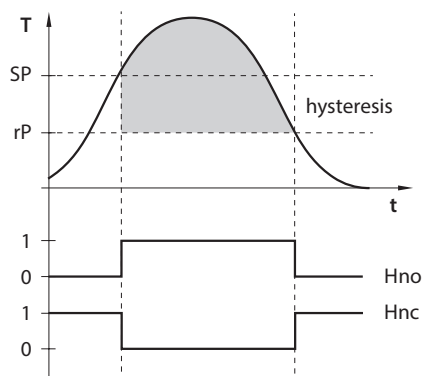

Fig. 8: Behavior of the switching output (hysteresis function)

### 3.5.6 Output functions — analog output

The analog output of the YSP sensors can be set as either a current or voltage output. The measuring range can be defined as required.

The minimum distance between the start and end point is 10 % of the set measuring range.

#### Current output

In the defined measuring range, the device supplies an analog current signal between ASP (analog start point) and AEP (analog end point). The following output configurations can be set:

- 4...20 mA (factory setting)
- 0...20 mA
- 20...4 mA
- 20...0 mA

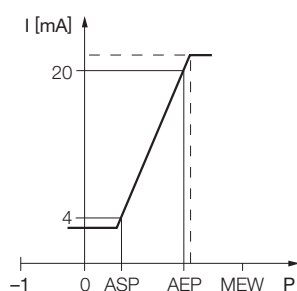

Fig. 9: Behavior of the current output (4... 20 mA)

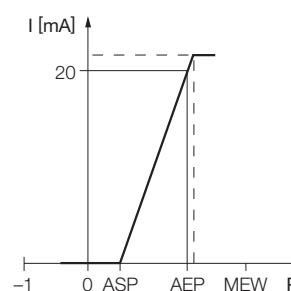

Fig. 10: Behavior of the current output (0...20 mA)

## Voltage output

In the defined measuring range, the device supplies an analog voltage signal between ASP (analog start point) and AEP (analog end point). The following output configurations can be set:

- 0...10 V
- 0...5 V
- 1...6 V
- 0.5...4.5 V
- 4.5...0.5 V (Not in Legacy Mode)
- 10...0 V
- 5...0 V
- 6...1 V

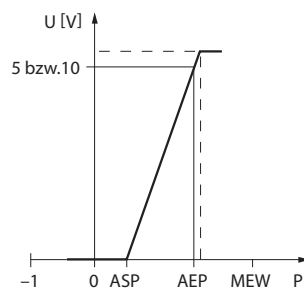

Fig. 11: Behavior of the voltage output (0...10 V or 0...5 V)

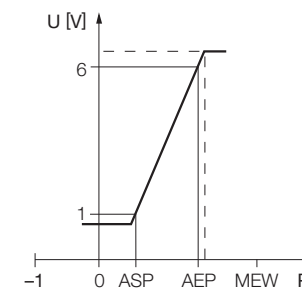

Fig. 12: Behavior of the voltage output (1...6 V)

### 3.5.7 Auto detect function

When connected to an I/O module, the device detects the pre-defined switching output behavior (PNP/NPN) or the analog output characteristic. The auto detect function is activated by default.

## 4 Mounting



### **DANGER**

Installation is pressurized  
**Risk of injury**

- ▶ Depressurize the installation before mounting.



### **NOTICE**

Pressure peaks  
**Damage to the measuring cell possible**

- ▶ Mount the device in a position in the installation at which no pulsating pressure or pressure peaks occur.
- ▶ If there are pressure peaks, only mount the device with a peak pressure aperture or accessories for overpressure areas.

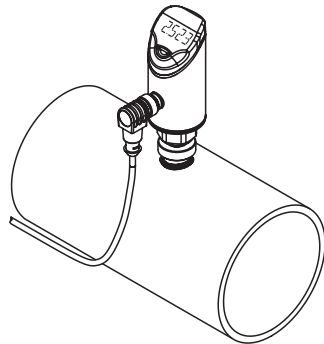

Fig. 13: Vertical mounting

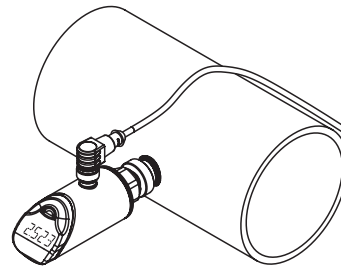

Fig. 14: Horizontal mounting

- ▶ Depressurize the installation before mounting.
- ▶ Do not mount the device in a location that is subject to high pressure pulses.
- ▶ Mount the device to the pressure connection using a suitable counterpiece as shown in the figure.
- ▶ Observe the different process connections.
- ▶ Mount the sensor in any orientation.
- ▶ The display can be rotated by 180°.
- ▶ The maximum tightening torque for fastening the sensor is 35 Nm (15 Nm for 7/16 UNF).
- ▶ The housing can be rotated 340°.

Significant temperature changes in the environment of the sensor can cause the zero point to drift. This means that the measured value displayed in a depressurized state is not zero. If the zero point has drifted, an offset value can be set via the COF parameter (see chapter “ [▶ 14]”).

## 5 Connecting

- ▶ Connect the female connector of the connection cable to the male connector of the sensor.
- ▶ Connect the open end of the connection cable to the power supply and/or processing units.

### 5.1 Wiring diagrams

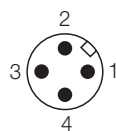

Fig. 17: Pin assignment

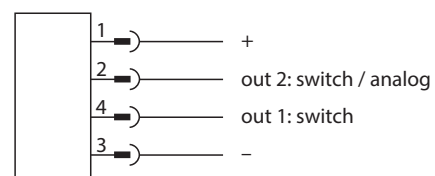

Fig. 18: Wiring diagram

## 6 Commissioning

The device is operational automatically once the power supply is switched on.

## 7 Operation



### WARNING

The enclosure can heat to over 75 °C (167 °F).

#### Risk of burns from hot enclosure surfaces!

- ▶ Prevent the enclosure from coming into contact with flammable substances.
- ▶ Prevent the enclosure from being touched unintentionally.

### 7.1 LEDs — operation

LED	Display	Meaning
PWR	Green	Device operational
FLT	Red	Error
bar	Green	Display in bar
psi	Green	Display in psi
kPa	Green	Display in kPa
MPa	Green	Display in MPa
MISC	Green	Other display unit
LOC	Yellow	Device locked
	Yellow flashing	"Lock/unlock" process active
	Off	Device unlocked
I and II (switching point LEDs)	Yellow	Switching output <ul style="list-style-type: none"> <li>■ NO: Switching point exceeded/within window (active output)</li> <li>■ NC: Switching point undershot/outside window (active output)</li> </ul>
	Off	Switching output <ul style="list-style-type: none"> <li>■ NO: Switching point undershot/outside window (inactive output)</li> <li>■ NC: Switching point exceeded/within window (inactive output)</li> </ul>

### 7.2 Display indications

Display	Meaning
----	Sensor failure
HW	Internal hardware fault
SC 1	Short circuit at output 1
SC 2	Short circuit at output 2
SC12	Short circuit at both outputs
WB 2	Wire break at current output 2
VOLT	Operating voltage outside the permissible range
LOAD	Load at the analog output outside the permissible range
Oor+	Value outside the measuring range, process value > 5 % of full scale above the measuring range

Display	Meaning
Oor-	Value outside the measuring range, process value > 5 % of full scale below the measuring range
Oor	No measurement data available
PArA	Incorrect user parameterization
TEMP	Device temperature outside the permissible range
Err	Unspecified error

## 8 Setting and parameterization

The device can be assigned parameters via touchpads (or factory set).

### 8.1 Settable functions and properties

The three front touchpads [ENTER], [MODE] and [SET] enable the user to set all the essential functions and properties directly on the device via the menu guidance..

Setting options — via touchpad

The following functions and properties can be set :

- Locking/unlocking the device
- Switching behavior:
  - Window mode
  - Single point mode
  - Two point mode
- Switching behavior in Legacy Mode:
  - Window function
  - Hysteresis function
- Analog range
- OUT1 output configuration : PNP/NPN, auto detection on/off
- OUT2 output configuration : PNP/NPN, auto detection on/off
- Advanced settings: Reset to factory settings.
- Advanced settings: Minimum and maximum value memory
- Advanced settings: Offset adjustment
- Advanced settings: Display color and behavior
- Advanced settings: Reset to presettings.
- Advanced settings: Set password.

## 8.2 Setting parameter values

### Standard menu

- ▶ Unlock the device when [MODE] or [SET] is touched, a red running light appears and the LOC LED is lit.
- ▶ Touch [MODE] or [SET] until the required parameter is displayed.
- ▶ Touch [ENTER] to select a parameter.
- ▶ Changing the displayed value: Touch [SET] for 3 s until the display stops flashing. Or: Touch [MODE] to return to the parameter selection.
- ▶ Increase or decrease the value gradually via [MODE] or [SET]. Certain values can be continuously changed by holding down [MODE] or [SET].
- ▶ Touch [ENTER] to save the modified value. The saved value flashes twice.

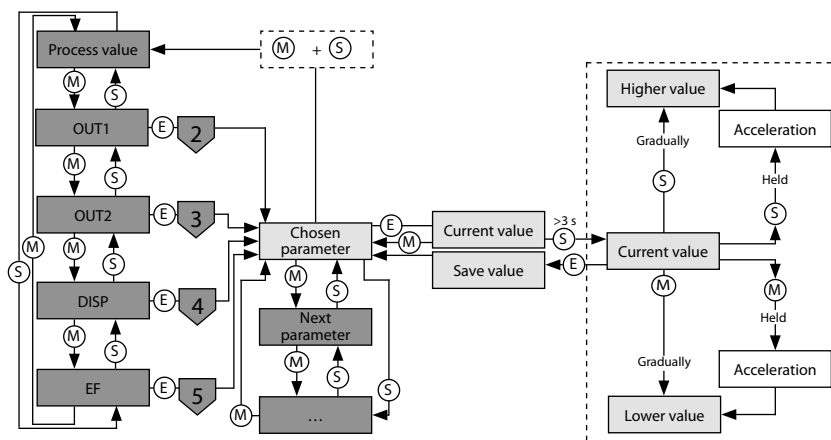

Fig. 19: Setting parameter values

## 8.3 Unlocking the device

- ▶ Touch [ENTER] for 3 s until all green bars are flashing on the display.
- ▶ Swipe [MODE], [ENTER], [SET] in succession: Two red flashing bars appear when each touchpad is touched. Once the two red bars have turned green, move onto the next touchpad without removing your finger from the touchscreen.
- ▶ Release the touchpads when six green bars are flashing on the display.
- ⇒ LOC LED goes off.
- ⇒ uLoc appears in the display and then disappears.

## 8.4 Locking the device

- ▶ Touch [MODE] and [SET] simultaneously for 3 s.
- ⇒ When the LOC LED flashes, Loc will appear on the display and then go out.
- ⇒ LOC LED is yellow.

The sensor is automatically locked if the touchpads of the device are not actuated for 1 min.

### 8.5 Protecting the sensor with a password

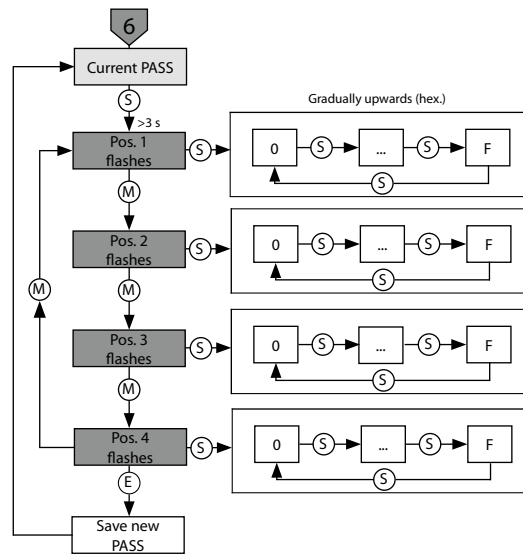

Fig. 20: Setting the password

### 8.6 Standard menu guidance

Use the [MODE] or [SET] touchpads to navigate through the main menu, as well as the OUT1 and OUT2 submenus, the EF extended functions menu and the DISP display menu. Press [ENTER] to select the respective submenu. Touching [MODE] and [SET] at the same time will cancel the parameter assignment. The device returns to the standard display.

In the EF menu, you can select Legacy Mode with its own menu guidance.

#### Standard menu guidance — main menu

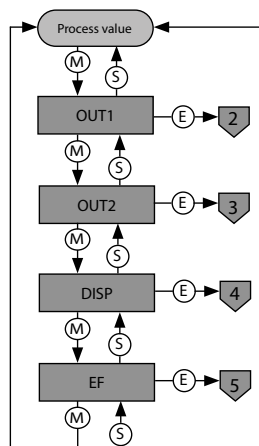

Fig. 21: Main menu

## Outputs (OUT...) submenu

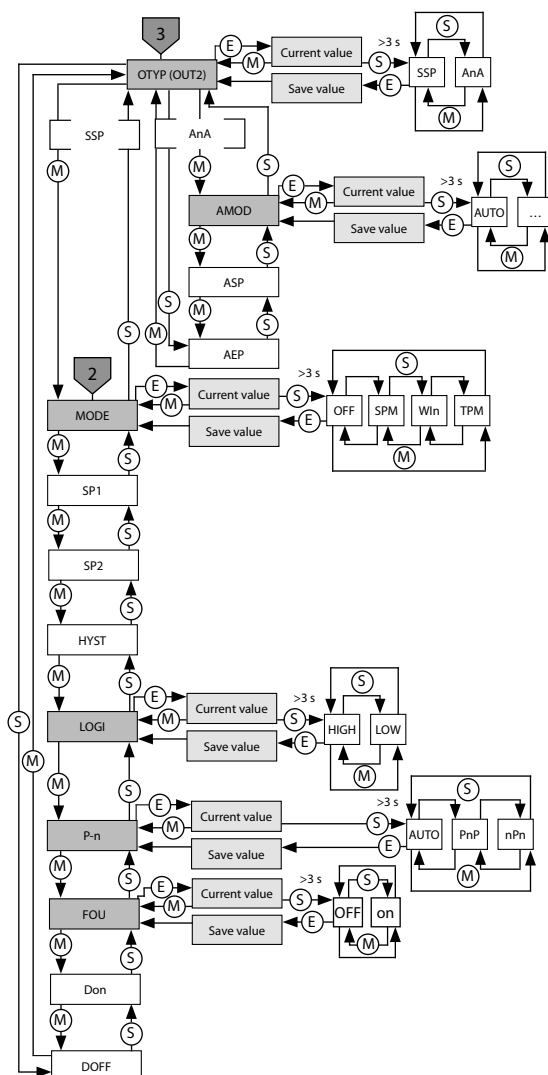

Fig. 22: Outputs (OUT...) submenu

## Display (DISP) submenu

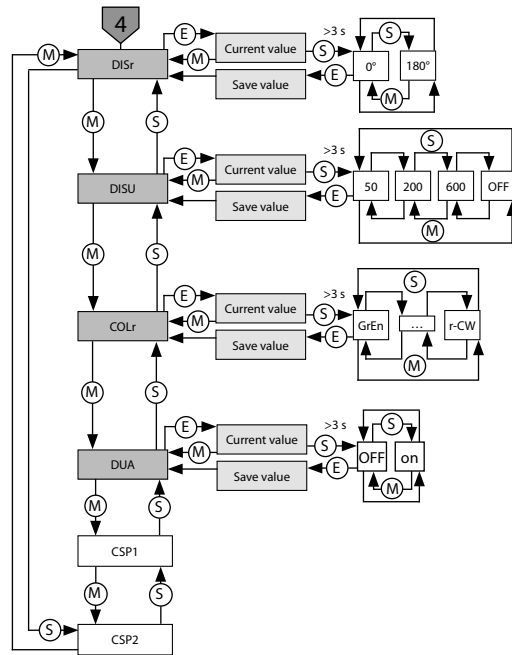

Fig. 23: Display (DISP) submenu

## Extended functions (EF) submenu

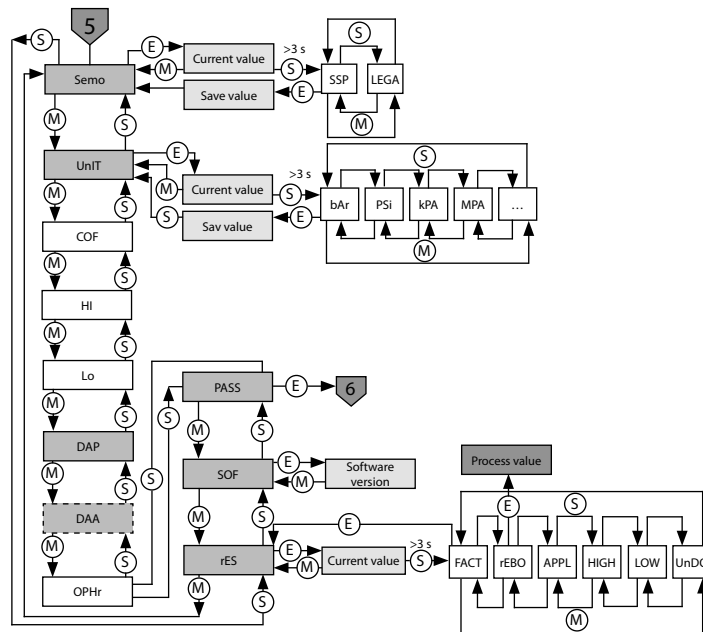

Fig. 24: Extended functions (EF) submenu

## 8.6.1 Parameters in the main menu

Default values are shown in **bold**.

	Explanation	Function
<b>OUT1</b>	Output 1 submenu	Switching output 1 setting options
<b>OUT2</b>	Output 2 submenu	Switching output 2 setting options or analog output
<b>DISP</b>	Display submenu	Refer to the "Parameters in the DISP submenu" table for additional setting options
<b>EF</b>	Extended Functions submenu	For additional setting options see the "Parameters in the EF submenu" table

## 8.6.2 Parameters in the OUT... (outputs) submenu

	Explanation	Options	Function
<b>OTYP</b>	Output Type (OUT2)	SSP	Switching output Smart Sensor Profile
<b>MODE</b>		<b>AnA</b>	Analog output
		OFF	
		SPM	Single Point Mode
		WIn	Window Mode
<b>SP1</b>	Switching point 1	<b>TPM</b>	Two Point Mode
			SPM: Limit value at which the switching output changes its switching state TPM: Upper limit value at which the switching output changes its switching state as the measured value rises WIn: Upper window limit at which the switching output changes its switching state <b>Default:</b> depends on pressure range
<b>SP2</b>	Switching point 2		SPM: not available TPM: lower limit value at which the switching output changes its switching state as the measured value falls WIn: lower window limit at which the switching output changes its switching state <b>Default:</b> depends on pressure range
<b>HYST</b>	Hysteresis		The min. hysteresis is depends on pressure range. The maximum hysteresis comprises the complete value range of the sensor. <b>Default:</b> depends on pressure range
<b>LOGI</b>	Invert switching logic	<b>HIGH</b>	0 → 1
		LOW	1 → 0
<b>P-n</b>	Behavior of the switching output	<b>AUTO</b>	Auto detection (NPN/PNP)
		PnP	N switching
		nPn	P switching
<b>Don</b>	Switch-on delay		0...60 s in increments of 0.1 s (0 = delay time not active) <b>Default: 0.0 s</b>
<b>DOFF</b>	Switch-off delay		0...60 s in increments of 0.1 s (0 = delay time not active) <b>Default: 0.0 s</b>

	Explanation	Options	Function
FOU	Behavior in the event of a fault (e.g. wire break or short circuit)	On	Switching output: The output is activated in the event of a fault. Analog output: Fault value of the set function at output 2 (OUT2)
		OFF	Switching output: The output is deactivated in the event of a fault. Analog output: Fault value of the set function at output 2 (OUT2)
AMOD	Analog output (only available for OUT2)	AUTO	Automatic detection (4...20 mA/0...10 V)
		4-20	4...20 mA
		0-20	0...20 mA
		20-4	20...4 mA
		20-0	20...0 mA
		0-10	0...10 V
		0-5	0...5 V
		1-6	1...6 V
		10-0	10...0 V
		5-0	5...0 V
		6-1	6...1 V
		0545	0.5...4.5 V
4505	4.5...0.5 V		
ASP	Start point of the analog signal		Measured value at which the analog output signal has its start point <b>Default:</b> depends on pressure range
AEP	End point of the analog signal		Measured value at which the analog output signal has its end point <b>Default:</b> depends on pressure range

### 8.6.3 Parameters in the DISP (display) submenu

	Explanation	Options	Function
DISr	Display orientation	0°	Display rotated by 0°
		180°	Display rotated by 180°
DISU	Display update	50	50-ms update time
		200	200-ms update time
		600	600-ms update time
		OFF	Display update deactivated
COLr	Display color	GrEn	Always green
		rED	Always red
		G1oU	Green if OUT1 is switched, otherwise red
		r1oU	Red if OUT1 is switched, otherwise green
		G2ou	Green if OUT2 is switched, otherwise red
		r2ou	Red if OUT2 is switched, otherwise green
		G-CW	Green if the process value is between the virtual switching points CSP1 and CSP2
		r-CW	Red if the process value is between the virtual switching points CSP1 and CSP2

	Explanation	Options	Function
DUA	Display	OFF On	Display of process value Alternating display of process value and unit
CSP1	Virtual upper switching point		Virtual upper switching point at which the display changes color (if display color G-CW or r-CW is selected) <b>Default:</b> depends on pressure range
CSP2	Virtual lower switching point		Virtual lower switching point at which the display changes color (if display color G-CW or r-CW is selected) <b>Default:</b> depends on pressure range

## 8.6.4 Parameters in the EF submenu (Extended Functions)

	Explanation	Options	Function
Semo	Set Mode	SSP LEGA	Smart Sensor Profile Legacy Mode
Unl	Display unit	bAr PSi kPA MPa Ud1-Ud10	bar psi kPa MPa Other units
COF	Offset adjustment		Significant temperature changes in the environment of the sensor can cause the zero point to drift. This means that the measured value displayed in a depressurized state is not 0. The drift can be corrected with the offset value. Setting range: -5...+5 % of the measuring range. <b>Default: 0</b>
HI	Maximum value memory		The highest measured value is stored and displayed.
Lo	Minimum value memory		The lowest measured value is stored and displayed.
DAP	Damping of the switching output		Filter for momentary or high frequency measurement peaks: 0...8 s in increments of 0.01 s <b>Default: 0.0 s</b>
DAA	Damping of the analog output		Filter for momentary or high frequency measurement peaks: 0...8 s in increments of 0.01 s <b>Default: 0.0 s</b>
OPHr	Operating hours counter		Display of operating hours in years (y), days (d) and hours (h)
PASS	Password protection	0000	Define password and activate password protection No password
SOF	Software version		Display the firmware version
rES	Reset	FACT rEBO APPL HIGH LOW UnDO	Reset the parameters to factory settings Restart the device (warm start) Reset application-specific data Reset the maximum value memory: The highest measured value is deleted. Reset the minimum value memory: The lowest measured value is deleted. Reset the parameters to the previous settings (last device start)

## 8.7 Legacy Mode

Use the [MODE] or [SET] touchpads to navigate through the main menu or the EF extended functions menu. Press [ENTER] to select the respective submenu. Touching [MODE] and [SET] at the same time will cancel the parameter assignment. The device returns to the standard display.

### Legacy Mode — main menu

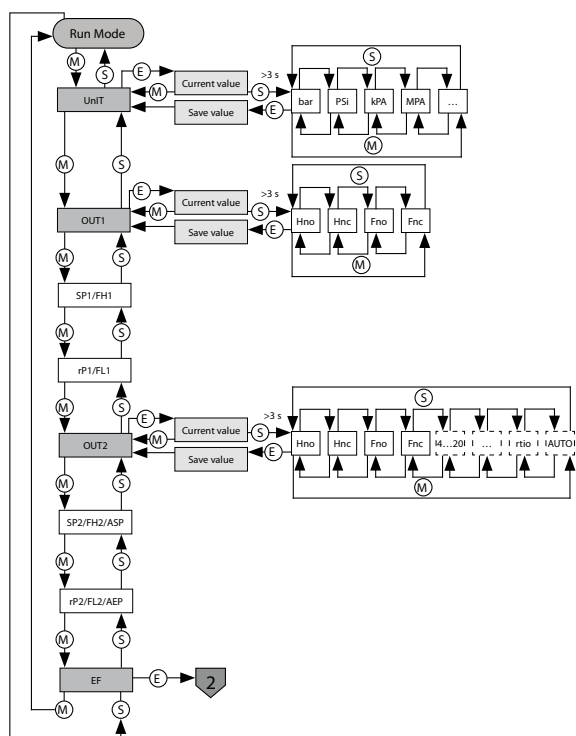

Fig. 25: Legacy Mode — main menu

## Legacy Mode — extended functions (EF) submenu

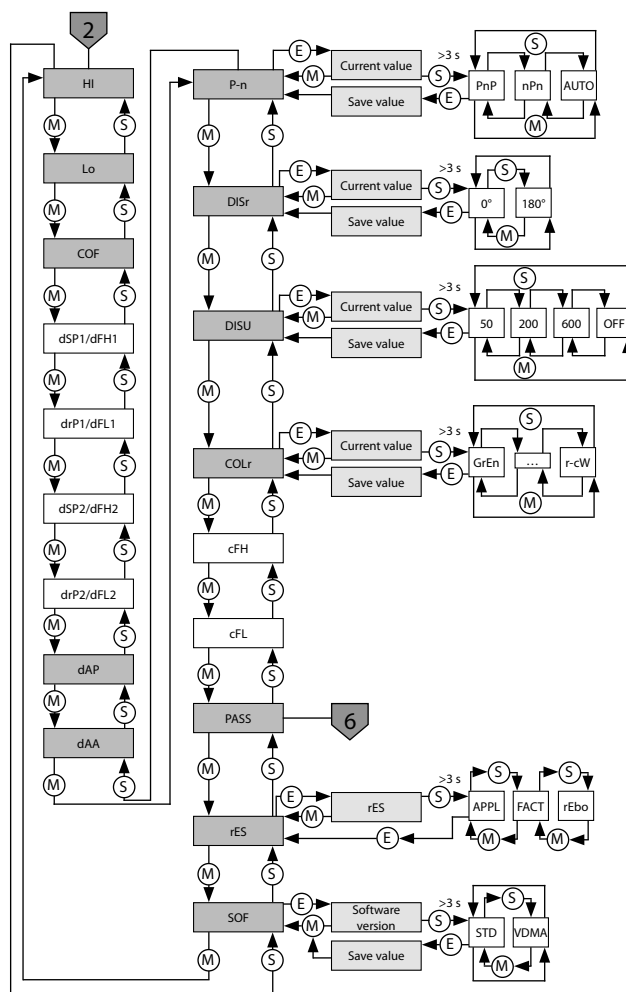

Fig. 26: Legacy Mode — extended functions (EF) submenu

## 8.7.1 Legacy Mode — parameters in the main menu

	<b>Explanation</b>	<b>Options</b>	<b>Function</b>
<b>UnIT</b>	Display unit	<b>bar</b>	bar
		psi	psi
		kPa	kPa
		MPa	MPa
		Ud1	mbar
		Ud2	Torr = mmHg (0 °C)
		Ud3	Inch of water (60 °F)
		Ud4	Inch of water (39 °F)
		Ud5	Foot of water (39 °F)
		Ud6	Inch of Hg (60 °F)
		Ud7	Inch of Hg (32 °F)
<b>OUT1</b>	Function of output 1	<b>Hno</b>	Hysteresis function (NO contact)
		Hnc	Hysteresis function (NC contact)
		Fno	Window function (NO contact)
		Fnc	Window function (NC contact)
		<b>SP1</b>	Switching point 1 for hysteresis function ou1: Hno/Hnc
<b>rP1</b>	Release point 1 for hysteresis function ou1: Hno/Hnc	Lower limit value at which output 1 changes its switching state when the pressure drops	
<b>FH1</b>	Upper switching point for window function ou1: Fno/Fnc	Upper switching point at which output 1 changes its switching state	
<b>FL1</b>	Lower switching point for window function ou1: Fno/Fnc	Lower switching point at which output 1 changes its switching state	

	<b>Explanation</b>	<b>Options</b>	<b>Function</b>
<b>OUT2</b>	Function of output 2	<b>Hno</b>	Hysteresis function (NO = normally open)
		Hnc	Hysteresis function (NC = normally closed)
	Window function	<b>Fno</b>	Window function (NO = normally open)
		Fnc	Window function (NC = normally closed)
	Analog output	<b>auto</b>	
		4-20	4...20 mA
		0-20	0...20 mA
		20-4	20...4 mA
		20-0	20...0 mA
		0-10	0...10 V
		0-5	0...5 V
		1-6	1...6 V
		10-0	10...0 V
5-0		5...0 V	
6-1	6...1 V		
rtio	0.5...4.5 V		
<b>SP2</b>	Switching point 2 ou2: Hno/Hnc		Upper limit value at which output 2 changes its switching state with rising pressure
<b>rP2</b>	Release point 2 ou2: Hno/Hnc		Lower limit value at which output 2 changes its switching state when the pressure drops
<b>FH2</b>	Upper switching point for window function ou2: Fno/Fnc		Upper switching point at which output 2 changes its switching state
<b>FL2</b>	Lower switching point for window function ou2: Fno/Fnc		Lower switching point at which output 2 changes its switching state
<b>ASP</b>	Start point of the analog signal ou2: Auto/analog values/rtio		Pressure level where the analog signal has its start point
<b>AEP</b>	End point of the analog signal ou2: Auto/analog values/rtio		Pressure level where the analog signal has its end point
<b>EF</b>	Sub-menu for additional setting options		See table "Parameters in the EF submenu"

## 8.7.2 Legacy Mode — parameters in the EF (extended functions) submenu

	<b>Explanation</b>	<b>Options</b>	<b>Function</b>
<b>Hi</b>	Maximum value memory		The highest pressure is stored and can be displayed/deleted here.
<b>Lo</b>	Minimum value memory		The lowest pressure is stored and can be displayed/deleted here.
<b>CoF</b>	Offset adjustment		Significant temperature changes in the environment of the sensor can cause the zero point to drift. This means that the measured value displayed in a depressurized state is not 0. This drift can be corrected. Setting range: -5 %...+5 % of the measuring range.

	Explanation	Options	Function
<b>dSP1</b>	Switching delay of SP1		0...60 s in increments of 0.1 s (0 = delay time not active)
<b>drP1</b>	Switching delay of rP1		0...60 s in increments of 0.1 s (0 = delay time not active)
<b>dFH1</b>	Switching delay of FH1		0...60 s in increments of 0.1 s (0 = delay time not active), only available with Window Mode Fno or Fnc
<b>dFL1</b>	Switching delay of FL1		0...60 s in increments of 0.1 s (0 = delay time not active), only available with Window Mode Fno or Fnc
<b>dSP2</b>	Switching delay of SP2		0...60 s in increments of 0.1 s (0 = delay time not active)
<b>drP2</b>	Switching delay of rP2		0...60 s in increments of 0.1 s (0 = delay time not active)
<b>dFH2</b>	Switching delay of FH2		0...60 s in increments of 0.1 s (0 = delay time not active), only available with Window Mode Fno or Fnc
<b>dFL2</b>	Switching delay of FL2		0...60 s in increments of 0.1 s (0 = delay time not active), only available with Window Mode Fno or Fnc
<b>dAP</b>	Damping the switching output (filter)		Momentary or high frequency pressure peaks can be filtered: 0...8 s in increments of 0.01 s (0 = filter is deactivated)
<b>dAA</b>	Damping the analog output		Momentary or high frequency pressure peaks can be filtered: 0...8 s in increments of 0.01 s (0 = delay time deactivated)
<b>P-n</b>	Behavior of the switching output	<b>auto</b> nPn PnP	Automatic detection of the output behavior n switching p switching
<b>diSr</b>		<b>0°</b> 180°	Display rotated by 0° Display rotated by 180°
<b>diSu</b>	Measured value display	50 <b>200</b> 600 OFF	50-ms update time 200-ms update time 600-ms update time Display update deactivated

	Explanation	Options	Function
<b>coLr</b>	Display color	<b>GrEn</b>	Display is always green
		rEd	Display is always red
		G1ou	Display is green if ou1 is switched, otherwise display is red
		r1ou	Display is red if ou1 is switched, otherwise display is green
		G2ou	Display is green if ou2 is switched, otherwise display is red
		r2ou	Display is red if ou2 is switched, otherwise display is green
		G-cF	Display is green if the measured value is between the switching points cFL and cFH
		r-cF	Display is red if the measured value is between the switching points cFL and cFH
<b>PASS</b>	Password protection		Define password and activate password protection
<b>rES</b>	Reset	<b>0000</b>	No password
		FacT	Reset the parameters to factory settings
		Undo	Reset the parameters to the previous settings (last device start)
<b>SOF</b>	Software version		Display the firmware version

## 9 Troubleshooting

If the device does not function as expected, first check whether ambient interference is present. If there is no ambient interference present, check the connections of the device for faults.

If there are no faults, there is a device malfunction. In this case, decommission the device and replace it with a new device of the same type.

If the device does not work as expected, proceed as follows:

- ▶ Exclude environmental disturbances.
- ▶ Check the connections of the device for errors.
- ▶ Check device for parameterization errors.

If the malfunction persists, the device is faulty. In this case, decommission the device and replace it with a new device of the same type.

## 10 Maintenance

Ensure regularly that the plug connections and cables are in good condition.

The devices are maintenance-free, clean dry if required.

## 11 Repair

The device is not intended for repair by the user. The device must be decommissioned if it is faulty. Observe our return acceptance conditions when returning the device to Georjin.

### 11.1 Returning devices

If a device has to be returned, bear in mind that only devices with a decontamination declaration will be accepted. This document is available through contact form at <https://georjin.com/en/formulaire-contacter-le-sav/> and must be completely filled in, and affixed securely and weather-proof to the outside of the packaging.

## 12 Disposal



The devices must be disposed of properly and do not belong in the domestic waste.



Designed, developed and manufactured in France  
Over 85 years of industrial expertise

Régulateurs GEORGIN  
14-16 rue Pierre Sépard – 92320 CHÂTILLON Cedex France  
Tel. : +33 (0)1 46 12 60 00 – Email : [regulateurs@georgin.com](mailto:regulateurs@georgin.com)

[www.georgin.com](http://www.georgin.com)